

x50G optoSiC+inclusiv glued mount for 12mm shaft

J = 127g*cm²
M = 54g

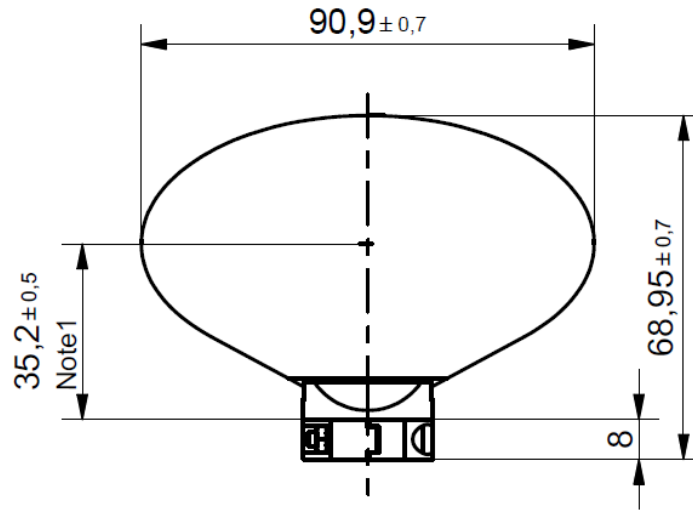
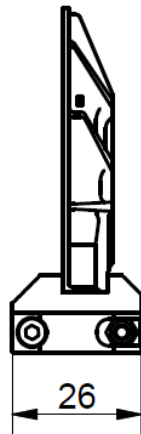

Mirror: X50

Notes:

1. Dimension from end of the galvo shaft to the center of the clear aperture.
2. Screw size = M3x20mm
3. Nut size = M3
3. Hex Key Size = 2,5mm
4. Recommended screw torque : 1,8Nm
5. Bore-Diameter 12H7

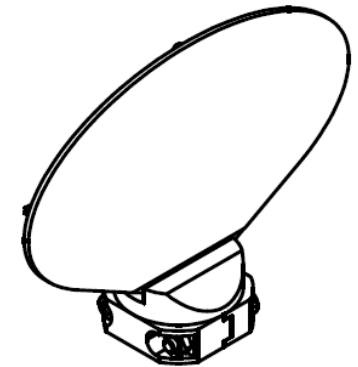

y50G optoSiC+inclusiv glued mount for 12mm shaft

$J = 184g \cdot cm^2$
 $M = 86g$

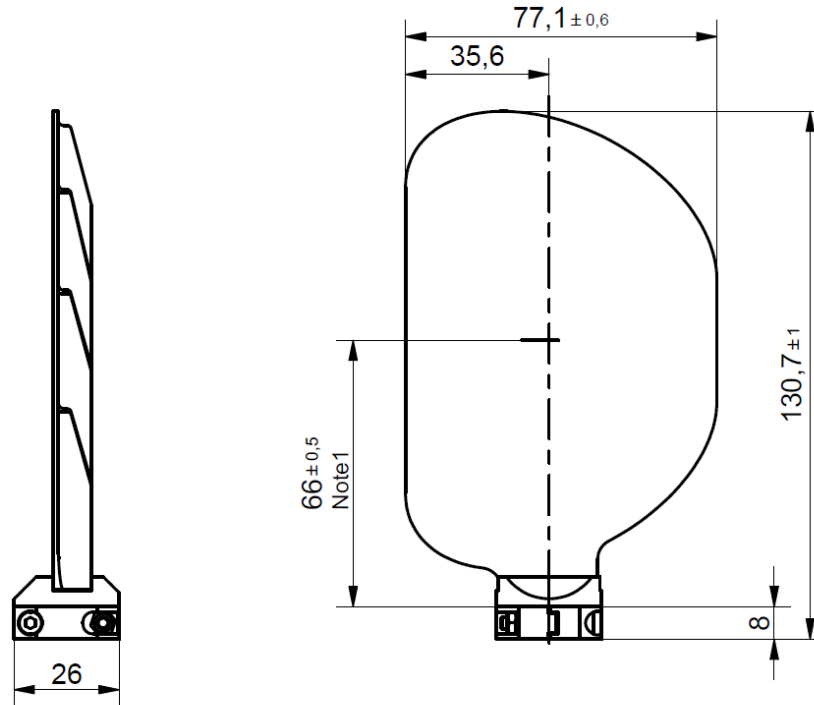

Mirror: Y50



Notes:

1. Dimension from end of the galvo shaft to the center of the clear aperture.
2. Screw size = M3x20mm
3. Nut size = M3
3. Hex Key Size = 2,5mm
4. Recommended screw torque : 1,8Nm
5. Bore-Diameter 12H7